



Survey

Hydrography

Dredging

Emergency

Product Catalogue



海亭同创

5



Company Profile

Beijing Hydro-Tech Marine Technology Co., Ltd. is a national high-tech enterprise which dedicates to hydrographic surveying and underwater exploring with core independent technologies and strive for continuous innovations. The company's Research and Development center is located in Beijing. And the application software center is in Qingdao. At the same time, the production and testing base is under construction in Tianjin.

Based on Hydro-Tech's product philosophy of Professional, Reliable, Differential and Innovation. We have successfully developed 6 product series of multibeam echo sounder, side scan sonar, imaging sonar, sound velocity sensor & profiler, inertial navigation systems and single beam echo sounder. Four major software platforms have been completed, including complete product controlling, standard surveying & navigation software, segment industry software and acoustic algorithms. With mature software and hardware technology increasing, now our company can provide not only Standardized Products, but also Customized Products.

In the future, our company will continue to strengthen its core technology, expand its automation and intelligence technology, and make more efforts to achieve the noble mission of "Make Underwater Exploration Work Easier".

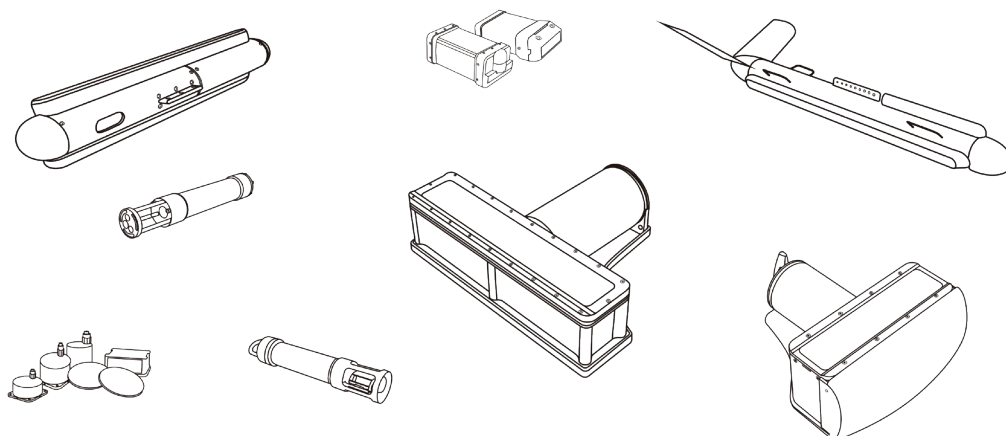

MS400P

MultiBeam Echo Sounder

Product Introduction

▶ MS400P is designed as a portable multibeam, which is easy to install and uninstalled onto various vessels for bathymetry application. Its size is quite small, while it has built-in sound velocity, and it can be easily operated by one hydrographer only. With good performance and reliable quality, MS400P had been widely used on all kinds of inflatable boats, survey vessel or other surface vehicles. It truly achieves easy installation, on-demand surveying as needed and as simple as a single beam echo sounder.



Specifications

Item	Parameter
Working Frequency	400kHz
No. of Beams	512
Depth Resolution	0.75cm
Swath Coverage	143°
Beam Width	1°×2°
Depth Range	0.2 ~ 200m+
Pulse Width	30us~8ms
Signal Type	CW/Chirp
Operating Modes	Equiangular / Equidistant
Max. Ping Rate	60Hz
Max. Working Depth	50m
Power Consumption	60W
Transducer Size	288mm×240mm×120mm
Transducer Weight	8.3kg (In the air)

* Depending on environmental conditions.

Product Features



High Performance

Beam Angel 1° x 2° | Number of Beams 512 | Resolution 0.75cm
IHO Standard Special Order



Low Power Consumption

Power Consumption is least 40W
working for 8 hours with an ordinary
storage battery



Small Size

288mm x 240mm x 120mm |
Similar to A4 paper | Easy to
carry in a backpack



Light Weight

Total system is weight around
10.3kg (Transducer 8.3kg / Deck
Unit 2kg) | Easy to hand carry
and quick to install.

Applications

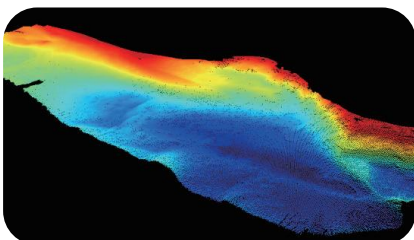

Inland Waterway Surveying

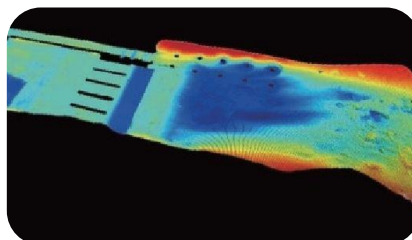

Underwater Infrastructure Inspection

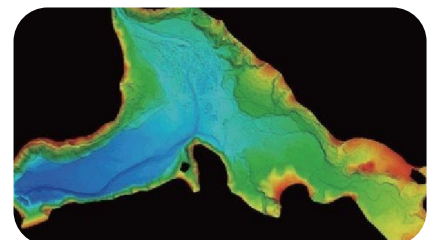

Reservoir Capacity Measurement

MS400U

MultiBeam Echo Sounder

Product Introduction

► MS400U is a compact multi-beam echo sounder specially designed for the integration of small USV or other unmanned platforms. It has built-in surface sound velocity sensor and attitude & heading measuring IMU sensor. For different applications, we can provide not only standard products in round or square shape, but also tailor-made for your special uncrewed USVs. With AutoSurvey function, MS400U simplified most setting up operation and is perfect for any hydro-graphic surveying requirement in the aspect of function and performance.

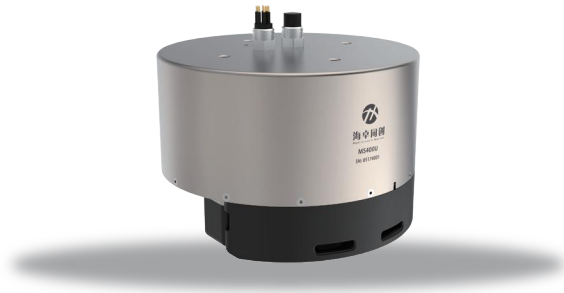

Specifications

Item	Parameter
Working Frequency	400kHz
No. of Beams	512
Depth Resolution	0.75cm
Swath Coverage	143°
Beam Width	1°×2°
Depth Range	0.2 ~ 200m+*
Pulse Width	30us~8ms
Signal Type	CW/Chirp
Operating Modes	Equiangular / Equidistant
Max. Ping Rate	60Hz
Max. Working Depth	50m
Power Consumption	80W
Transducer Size	φ220mm×181mm (Round Version) φ205×205×181mm (Square Version)
Transducer Weight	7.5kg

* Depending on environmental conditions.

Product Features



Highly Functional Integration

Integrate high-precision satellite positioning system, attitude & heading IMU and sound velocity sensors, which can realize non-calibration underwater terrain survey and provide positioning information to USV.



Full automatic Non-calibration

Automatic measurement without adjustment and manual intervention is suitable for all kinds of unmanned platform integration applications.



Low Consumption Light Weight

Power Consumption is least 80W. Weight around 7.5kg. Easy to install. Suitable for ROV/AUV/USV to underwater terrain surveying.



Extension Functions

Independent and extensible network interface. It can work together with side scan sonar, ADCP & 3D laser scanning system or other sensor.

Applications

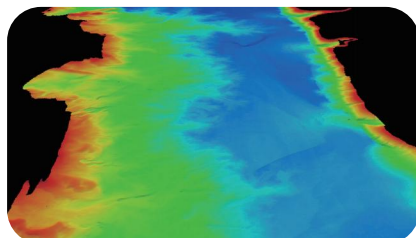

USV Underwater Terrain Survey

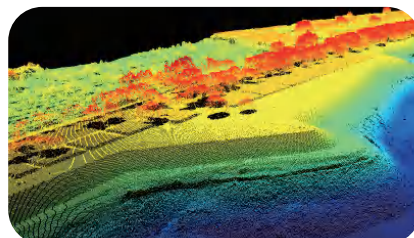

Above and Underwater 3D Mapping

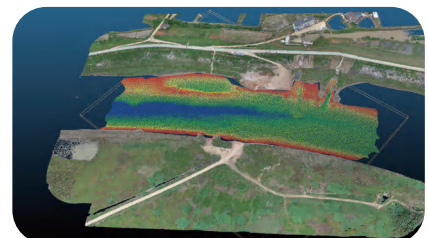

Urban Waterway Rapid Measurement

MS8200

200kHz Multibeam Echo Sounder

Product Introduction

▶ MS8200 is specially designed for professional oceanographic mapping and deep channel surveying. It combines with 200kHz basic frequency and Hydro-Tech unique algorithm. MS8200 does deliver not only reliable performance, but also with the most advanced technologies. It can work well even in harsh environment.

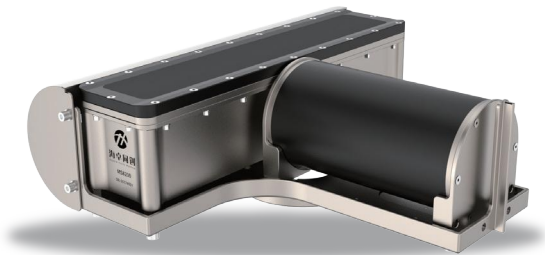

Specifications

Item	Parameter
Working Frequency	200kHz
No. of Beams	512
Depth Resolution	0.75cm
Swath Coverage	160°
Beam Width	1°×2°
Depth Range	0.5 ~ 500m+
Pulse Width	15us~8ms
Signal Type	CW/Chirp
Operating Modes	Equiangular / Equidistant
Max. Ping Rate	60Hz
Max. Working Depth	50m
Power Consumption	80W
Transducer Size	500mm x 457mm x 147mm
Transducer Weight	22.6kg (In the air)

* Depending on environmental conditions.

Product Features



Efficiency

160° Swath Coverage | Working Range is more than 8 Times of Depth | Ping Rate 60Hz|Max sounding depth reaches 400m



One System Multi-function

3D Underwater Terrain Surveying | Water Imaging | Multi-Objects Detection



Diverse Water Area Survey

River or coastline, clear or muddy water fine structure or big range surveying, all can get accurate result through adjusting working modes

Applications

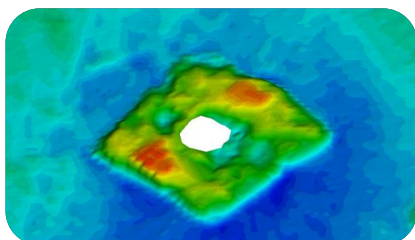

Wind Turbine Foundation Scour Detection

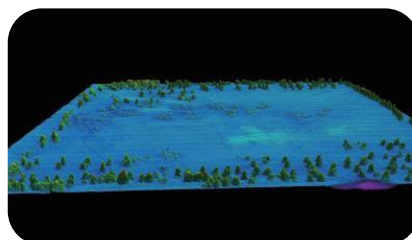

Coral Reef Distribution Survey

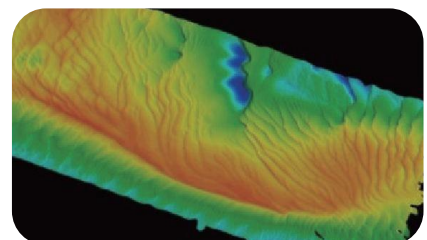

Big Scope of Deep Sea Bathymetry

MS400P-PT

Underwater Infrastructure 3D Monitoring

Product Introduction

- MS400P-PT is a multibeam echo sounding system, its transducer can be installed inclinedly and 3D real-time monitor the construction situation with 360° rotation. At the same time, it also has the traditional navigation and surveying function, or being fixed at some stand-alone point to scan the terrain changing. It is a software and hardware integrated solution and designed specifically for typical applications such as dredging, stone throwing monitoring, and erosion inspection of bridge.

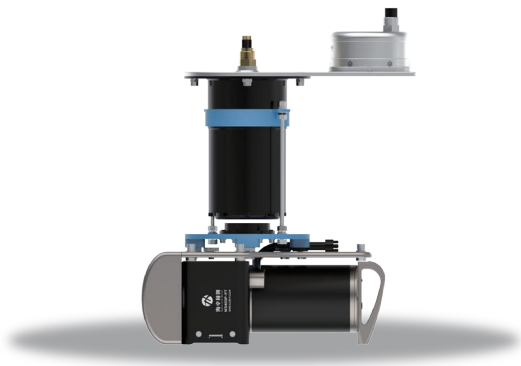

Specifications

Item	Parameter
Working Frequency	400kHz
No. of Beams	512
Depth Resolution	0.75cm
Swath Coverage	143°
Beam Width	1°×2°
Depth Range	0.2 ~ 200m*
Max. Ping Rate	60Hz
Max. Working Depth	50m
Power Consumption	80W
Rotation Angle	0~360°
Rotation Velocity	0~3RPM
Rated Torque	30Nm

* Depending on environmental conditions.

Product Features



Large Swath Coverage High Efficiency

High precision dual axis gimbal supports automatic tilt measurement and 360° rotation measurement. It can greatly improve the efficiency of fixed and mobile measurement.



Multi-scenario Engineering Application

Integrated acoustic hardware and professional pan tilt control software to ensure the system able to be fixed installation for underwater 3D monitoring and for routine terrain bathymetry through mobile measurement.



Specialized Software Design

An operation software designed specifically for underwater 3D construction monitoring can display real-time changes in underwater 3D scenes, achieve 4D data display, and precise construction monitoring.



User-Friendly and Portable Operation

The software and hardware system is designed for the operation habits of the site construction personnel, and the operation is simple, the display is intuitive and the project application is fast.

Applications

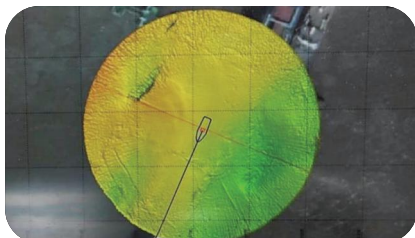

Real-time Riprap Survey

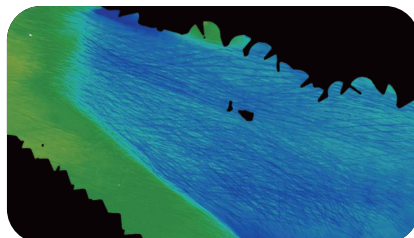

Visual Suction Surface

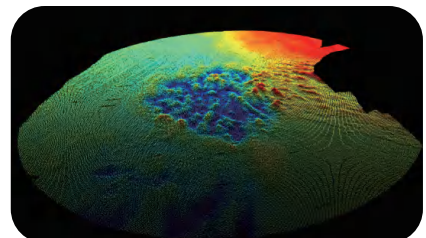

Real-time Dredging Monitoring

MS400P-W | MS400U-W | MS8240

Broad Band Frequency Multibeam Echo Sounder

MS400P-W



• Specifications

Item	Parameter
Working Frequency	200kHz~400kHz/700kHz
No. of Beams	512
Depth Resolution	0.75cm
Swath Coverage	143°
Beam Width	1°×1°@400kHz
Depth Range	0.2~200m+
Pulse Width	30us-8ms
Signal Type	CW/Chirp
Working Modes	Equiangular / Equidistant
Max. Ping Rate	60Hz
Max. Working Depth	50m
Power Consumption	90W

* Depending on environmental conditions.

MS400U-W

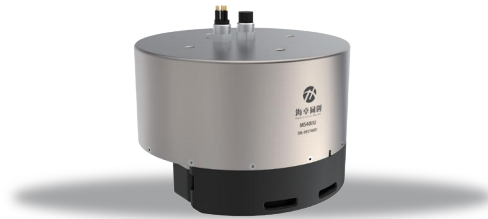

• Specifications

Item	Parameter
Working Frequency	200kHz~400kHz/700kHz
No. of Beams	512
Depth Resolution	0.75cm
Swath Coverage	143°
Beam Width	1°×2°@400kHz
Depth Range	0.2~200m+
Pulse Width	30us-8ms
Signal Type	CW/Chirp
Working Modes	Equiangular / Equidistant
Max. Ping Rate	60Hz
Max. Working Depth	50m
Power Consumption	90W

* Depending on environmental conditions.

Applications

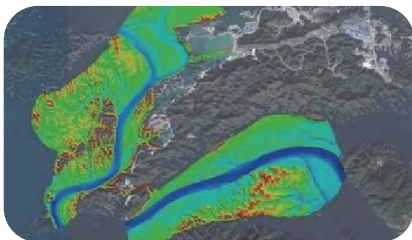

Underwater Terrain Mapping

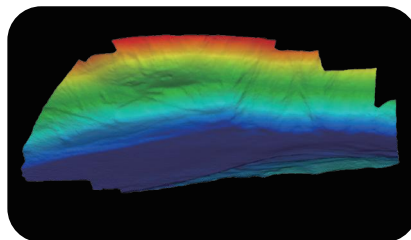

Reservoir Capacity Measurement

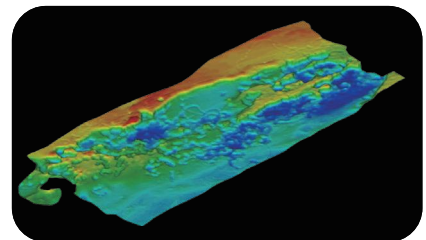

Sand Mining Survey

Product Introduction

- ▶ MS400P-W, MS-400U-W & MS8240 can achieve online continuously adjustment of 200kHz~400kHz and also support high frequency of 700kHz. With high resolution and convenient operation. They can fully adapt to complex terrain and multi-scene application environment and complete fine measurement in shallow water area. With large-scale sweeping and rapid operation, these three models could be widely used in various inland rivers, reservoirs, lakes and shallow sea survey & mapping projects.

MS8240

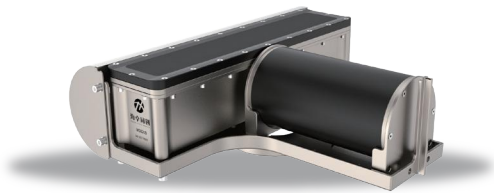

Specifications

Item	Parameter
Working Frequency	200kHz~400kHz/700kHz
No. of Beams	512
Depth Resolution	0.75cm
Swath Coverage	143°
Beam Width	0.5°*1°@400kHz
Depth Range	0.5~500m+
Pulse Width	30us~8ms
Signal Type	CW/Chirp
Working Modes	Equiangular / Equidistant
Max. Ping Rate	60Hz
Max. Working Depth	50m
Power Consumption	90W

* Depending on environmental conditions.

Product Features



Real-time Adjustment

Online continuous step 10kHz adjustable frequency, perfectly balance the relationship of measurement accuracy and operating distance.



Anti-interference Capability

Adopting frequency modulation technology which has strong anti-interference ability and can work stably in complex underwater environments.



Multi-function

With a variety of measurement functions such as water depth measurement, seabed terrain rendering, object detection, etc. to meet the needs of different application scenarios.



Excellent Quality

Years of system and algorithm research to ensure reliable and stable data quality

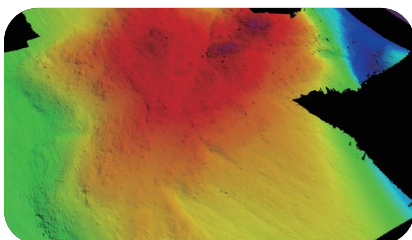

Accurate Seabed Scanning

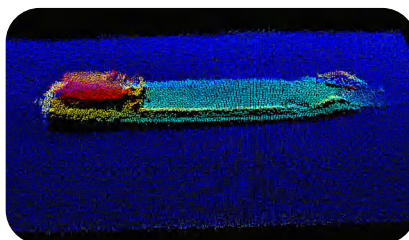

Underwater Object Searching

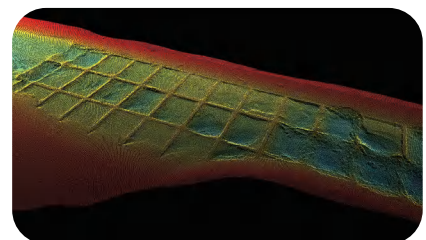

Penn's Cage Detection

MS400P-IDH

Integrated Dual Head Multibeam Echo Sounder

Product Introduction

- ▶ MS400P-IDH Multibeam Echo Sounder is a big swath and high-precision solution perfect for water transportation, channel dredging, island and reef measurement, and shore slope maintenance. For inland canal, tidal zones and other shallow water areas, it solves the problem of data acquisition in blind spots areas where traditional MBES is difficult to survey.



Specifications

Item	Parameter
Working Frequency	400kHz
No. of Beams	1024
Depth Resolution	0.75cm
Swath Coverage	200°
Beam Width	1°×2°
Depth Range	0.2~200m*
Pulse Width	30us~8ms
Signal Type	CW/Chirp
Operating Modes	Equiangular / Equidistant
Max. Ping Rate	60Hz
Max. Working Depth	50m
Tilt Angle	30°

* Depending on environmental conditions.

Product Features



Shallow Water Large Sweep Width

6 meters water depth environment support more than 10 times the depth of the sweep width, greatly improve the field scanning efficiency



High-precision Measurement

MS400P original acoustic performance with POS high precision inertial navigation combination and enhance stable and reliable accuracy.



Software Algorithm Upgraded

Support HydroQQuest & HydroNavi software, compatible with single and dual head modes

Applications

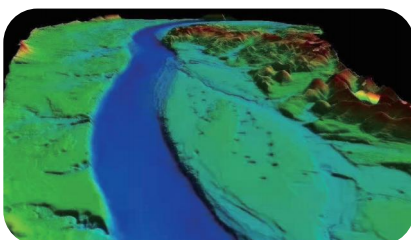

Inland Waterway Surveying

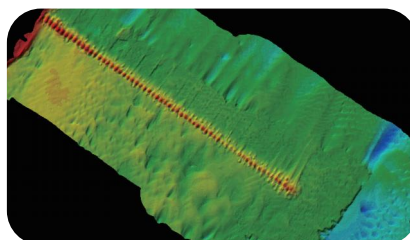

Channel Maintenance Survey

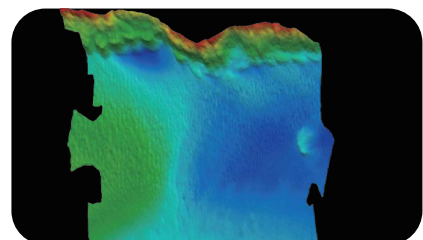

Underwater Infrastructure Inspection

MS8200-IDH

Integrated Dual Head Multibeam Echo Sounder

Product Introduction

- MS8200-IDH is a complete and powerful multibeam echo sounder with 1024 beams per ping, allowing for bigger swath performance and higher survey efficiency under challenging acoustic conditions. Unprecedented clean bathymetry data reduced processing complexity and make survey operation easier and faster. Dual heads enable multiple detections of increased target details and very advanced beamforming modes.



Specifications

Item	Parameter
Working Frequency	200kHz
No. of Beams	1024
Depth Resolution	0.75cm
Swath Coverage	220°
Beam Width	1°×2°
Depth Range	0.5~500m+*
Pulse Width	30us~8ms
Signal Type	CW/Chirp
Operating Modes	Equiangular / Equidistant
Max. Ping Rate	60Hz
Max. Working Depth	50m
Tilt Angle	30°

* Depending on environmental conditions.

Product Features



Efficiency Upgrade

Dual heads mode means that the swath width is increased by twice. So surveyor can greatly reduce the field working time and increase work efficiency



Well-adapted

According to different measuring environment and demand, the parameters such as beam width and frequency can be adjusted to obtain better measurement results



Fully Automatic Measurement

Simplify the field operation process and truly make the underwater exploration work better

Applications

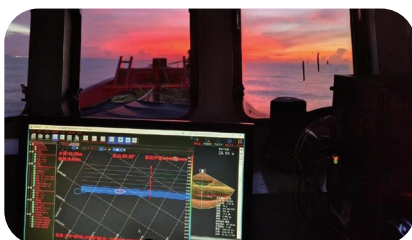

Large-scale Seabed Survey

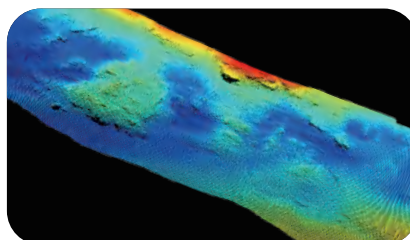

Offshore Construction Monitoring

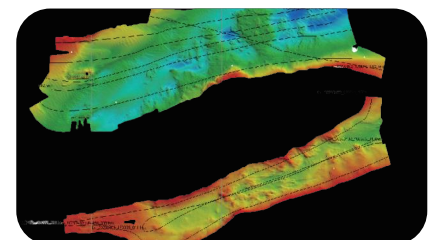

Wide Range Channel scan

SS3060 / SS4090

Dual Frequency Side Scan Sonar

Product Introduction

- ▶ SS3060 and SS4090 is a dual-band broadband high-definition side-scan sonar designed for general survey requirement. The system adopts a number of innovative technologies including broadband signal processing variable aperture, image equalization, 4K HD display technology to fulfill customer requirements on wide scanning range and high definition



Specifications

Item	Parameter
Working Frequency	300kHz / 600kHz (SS3060)
	400kHz / 900kHz (SS4090)
Max. Slope Range	230m * kHz@300kHz; 150m * kHz@400kHz
Parallel Beam Width	0.2°@900kHz; 0.26°@600kHz
Vertical Beam Width	50°
Along Track Resolution	600kHz: 0.09m@20m; 0.23m@50m; 0.34m@75m
	900kHz: 0.07m@20m; 0.17m@50m; 0.26m@75m
Across Track Resolution	1.25cm@600kHz; 1cm @900kHz
Signal Type	CW/Chirp
Max. Working Depth	300m
Auxiliary sensor	Pressure, roll, pitch & heading
Power Supply	DC 20V - 36V / AC 110V - 240V
Power Consumption	60W
Software	HydroSonar

* Depending on environmental conditions.

Product Features



High Resolution

With 60kHz bandwidth signal, SS3060 and SS4090 adopt pulse compression or ultra short pulse transmission to improve the ranging resolution in the across track direction from the system level and enhance scanning image resolution too.



Clear Image Near or Far

It adopts variable aperture dynamic focusing technology to increase scanning image's depth of field and effectively resolve near field blur problem of general side scan sonars, SS3060 and SS4090 can get clear and consistent image from both far and close range.



Delicate Image

Innovative image equalization technology combines software of real-time contrast adjusting and hardware of 24bits high dynamic AD to enhance the image contrast and definition. This is the reason that SS3060 and SS4090 can present the terrain background image so delicately.

Applications

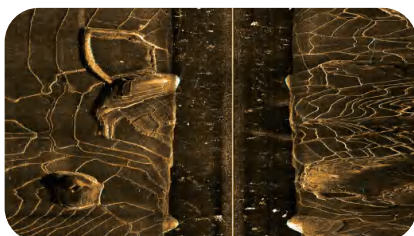

Seabed large Area Sweeping

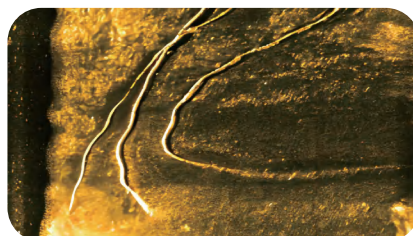

Submarine Cable Routing Survey

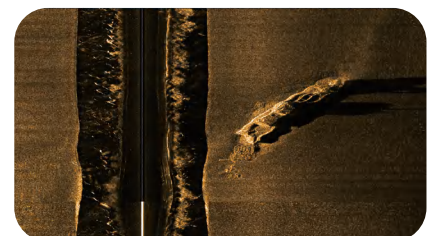

Underwater Archeology

SS900

Single Frequency Side Scan Sonar

Product Introduction

- ▶ SS900 is a towfish side scan sonar specifically designed for emergency and rescue application. With the leading self-adaption wave adjustment technology combining broadband signal processing and image equalization technology, it can clearly detect various underwater small targets and complex structures.

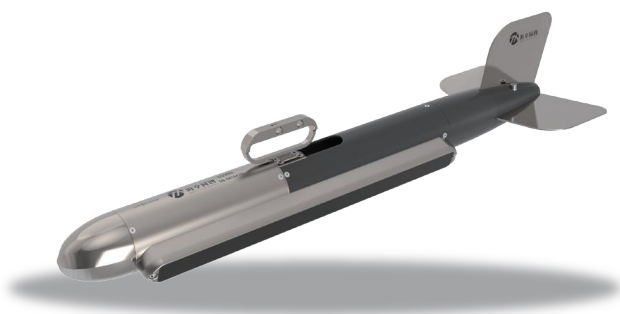

Specifications

Item	Parameter
Working Frequency	900kHz
Max. Slope Range	75m@900kHz
Parallel Beam Width	0.2°@900kHz
Vertical Beam Width	50°
Along Track Resolution	0.07m@20m; 0.17m@ 50m; 0.26m@75m
Across Track Resolution	1cm@900kHz
Signal Type	CW/Chirp
Max. Working Depth	300m
Auxiliary sensor	1cm@900kHz
Power Supply	DC 20V - 30V / AC110V - 240V
Power Consumption	15-35W
Software	HydroSonar

* Depending on environmental conditions.

Product Features



Compact Design for Multiple Applications

Small size and light weight. It is easy for hand carry and operation. Meet the rapid response requirements for inland engineering and waterway obstacle detection.



Auto Survey and High Definition Image

Support auto survey mode, 4K high-definition image display, directive visualization of results. Greatly reduce the professional requirements of hydrographic surveyor personnel.



Easy Operation and Quick to Use

Three-step connection can be carried out rapidly, suitable for all kinds of inflatable boats, speed boats and other water surface vessels.

Applications

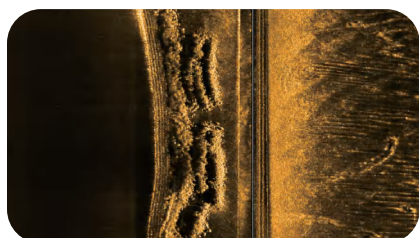

Underwater Construction Inspection

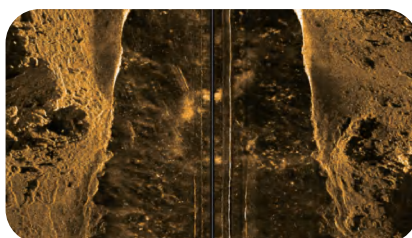

Navigation Obstruction Detection

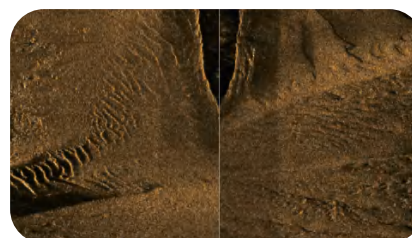

Underwater Geomorphologic Survey

MSS300

Multibeam Side Scan Sonar

Product introduction

- ▶ MSS300 is designed specifically for high-definition imaging of small objects in water at high speed. It maximumly supports 9 knots and forms 20 beams. It can be deployed onto various platforms to work underwater. The applications cover many fields including port & harbor security, marine investigation and underwater archaeology etc.

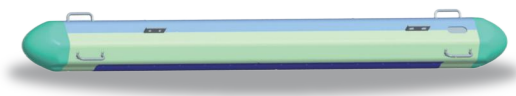

Specifications

Item	Parameter
Working Frequency	300kHz
Max. Slope Range	250m@300kHz
Parallel Beam Width	0.25°@300kHz
Vertical Beam Width	40°
Along Track Resolution	0.44m@100m; 0.87m@200m
Across Track Resolution	3.8cm@300kHz
Signal Type	CW/Chirp
Max. Working Depth	300m
Auxiliary Sensor	Compact Data Recorder
Towfish/Transducer Size	1400mm×96mm×37.8mm
Towfish/Transducer Weight	68kg
Max. Velocity	6m/s

* Depending on environmental conditions.

Product Features



High Speed Mode

MSS300 supports up to 9 knots and can detect the small target in water real-time. It simultaneously generates 20 sonar beams at the same time, which make the scanning image turn to be very dedicated.



Dynamic Focusing

With dynamic focusing technology, MSS300 can quickly capture all objects clearly no matter near or far even during quick movement. Its along-track and across track resolution is high enough to cm level. The adoption of multi-beam technology can greatly improve the efficiency of surveying and mapping.



Supreme Anti-Interference High-definition Image Clarity

The software and hardware system is designed for the operation habits of on-site construction personnel, with simple operation, intuitive display, and quick application in engineering.

Applications



Large Area Underwater Survey

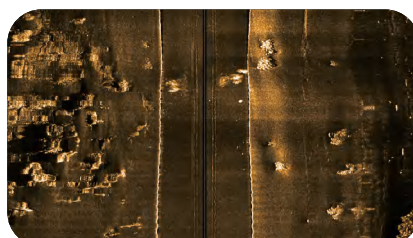

Obstacle Scanning



Underwater Structure Inspection

ES Series (ES900M, ES900, ES4590)

Embedded Side Scan Sonar

Product Introduction

ES Series' working frequency range from 450 to 900kHz. The system has standard or customized version of single-frequency or dual-frequencies, different size and shape. It adopts self-adaptive wave adjustment technology combine broadband signal processing and image equalization technologies. It can clearly scan the image of small objects and complex underwater infrastructure. This is very helpful for underwater security and small target detection applications.

ES900M



ES900



ES4590



Specifications

Item	ES900M	ES900	ES4590
Working Frequency	900kHz	900kHz	450kHz
Max. Slope Range	75m' @900kHz	75m' @900kHz	150m' @450kHz
Parallel Beam Width	0.4° @900kHz	0.2° @900kHz	0.2° @900kHz
Vertical Beam Width	40°	50°	50°
Along Track Resolution	0.14m@20m;0.35m@50m	0.07m@20m;0.17m@50m;0.26m@75m;	0.07m@20m;0.17m@50m;0.26m@75m (900kHz)
Across Track Resolution	1cm	1cm	1cm
Signal Type	CW/Chirp	CW/Chirp	CW/Chirp
Max. Working Depth	1000m	1000m	1000m
Auxiliary Sensor	Compact Data Recorder	Compact Data Recorder	Compact Data Recorder
Power Supply	DC12-30V	DC12-30V	DC12-30V
Power Consumption	10W-30W	10W-30W	10W-30W
Software	Hydro Sonar & SDK	Hydro Sonar & SDK	Hydro Sonar & SDK

* Depending on environmental conditions.

Product Features



Embedded Platform

ES series of side scan sonar has the features of small size, light weight, low power consumption. Its structure is simple, operation is easy, which is suitable for integration application. With different frequency, diversified shape and connector, ES series can meet the SDK requirements of various small USV, ROV and AUV.



Compatible with Various Applications

ES Series is compatible with various devices via Ethernet cable RS232 COM port. Realize multi-module combination and collect all types of data of different sensors. It provides 8 output of sync signal by programmable TTL, which efficiently resolve complex sound interfering and synchronization control problem.



High Resolution Image

Innovative transducer design and advanced self-adaptive wave form adjustment technology combining broadband signal processing & image equalization technology, ES series side scan sonar can provide a larger scanning range and high-definition results.

Applications



USV



ROV



AUV

IS720M

Imaging Sonar

Product Introduction

▶ IS720M is a dual-frequency imaging sonar with ultra-small size, low power consumption and easy for integration. It adapts state of art industry design and multi-beam algorithm to get high-resolution image underwater. We target to reach the video-grade acoustic imaging clarity and with high update rate, which meet various ROV/AUV requirement to target detection, obstacle avoidance and divers' need to underwater imaging & navigation function.



Specifications

Item	Parameter
Working Frequency	720kHz
Number of Beams	512
Beam Width	1°/0.6°
Beam Separation	0.25°
Horizontal Sector	130°
Vertical Sector	20°
Maximum Detecting Range	120m
Minimum Detecting Range	0.1m
Range Resolution	4mm
Update Rate	Up to 40Hz
Signal Type	CW / Chrip
Power Supply	11 - 32V DC
Power Consumption	30 - 45W
Data Interface	Ethernet & RS485 Sync
Depth Rating	350m

* Depending on environmental conditions.

Product Features



Excellent Performance

The horizontal receiving beam Angle is 0.4° and the number of beams is 512. The range resolution 2.5mm, IS720 expand the imaging range or high resolution at the user's optional setting. IS720 adopts real-time dynamic focus beamforming technology to ensure the balance of long-distance detection and high-definition imaging.



Light and Compact

The weight of the whole device is only 3.4kg, the power consumption is less than 50W. IS720 is suitable for all kinds of small uncrewed platform of AUV & ROV to obstacle avoidance.



Easy Deployment

IS720 offers high-definition image quality in a small and rugged cover. Designed for integration onto any platforms from small inspection-class ROVs to larger working-class vehicles, it can work down to 350m depth. IS720 is ready to any challenge in water.

Applications



Vessel Obstacle Avoidance



Underwater Security



Bridge Pier Damage Detection

SVS1500M

Sound Velocity Sensor

Product Introduction

- ▶ SVS1500 sound velocity sensor adopts "Time Leap" technology for sound velocity measurement. Combining with advanced digital signal processing technology, the sound velocity measuring accuracy can reach 0.05m/s.



Specifications

Item	Parameter
Sound Velocity Range	1400m/s~1600m/s
Sound Velocity Resolution	0.001m/s
Sound Velocity Accuracy	±0.05 m/s
Sampling Rate	1-30Hz
Max. Working Depth	300m
Data Port	RS232
Baud Rate	2400bps~115200bps
Power Supply	12V
Size	Φ34mm x 163.5mm
Weight	0.6kg

Product Features



Quick Response

Highest output rate can reach 30Hz data which means SVS1500 can rapidly feedback to abnormal water current and sound velocity changing in some waterfield, so that it can provide accurate calibration to sound velocity.



Stable Performance

Adopt up-to-date sound velocity sensor, new material & measuring technology, SVS1500 greatly minimize the impact caused by environment in order to ensure the data performance.



Easy Operation

Plug and play mode is suitable for out field application. It can work quickly with Laptop and various echo sounder, or integrated with other sound velocity measuring parts.

Applications



SVP1500

Sound Velocity Profiler

Product Introduction

- ▶ SVP1500 sound velocity profiler adopts "Time Leap" technology for sound velocity measurement. The system measuring accuracy reaches 0.05m/s. It has integrated a high-precision pressure sensor. The depth accuracy can reach 0.15m, which is the world leading level.



Specifications

Item	Parameter
Sound Velocity Range	1400m/s~ 1600m/s
Sound Velocity Resolution	0.001m/s
Sound Velocity Accuracy	±0.05 m/s
Sampling Rate	1-30Hz
Temperature Sensor Type	PT1000
Temperature Range	0~40°C
Temperature Resolution	0.001°C
Temperature Accuracy	±0.05°C
Depth Accuracy	0.15m
Depth Resolution	0.01m
Max. Working Depth	200m
Data Port	USB
Size	Φ75mm x 425mm
Weight	3.2kg (In the air) / 1.8kg (In water)

Product Features



High Accuracy

With "Time Leap" technology, SVP1500's accuracy was enhanced to 0.05m/s. Built-in high-precision pressure sensor, depth accuracy reaches 0.15m.



Long Battery Life

Built-in high-performance lithium battery continuous working life is longer than 8 hours. It is much easier to maintain.



Easy Operation

16GB massive storage space, which can store at least 4000 hours of data.



High Sampling Rate

The sound velocity measuring time interval is shorter, which improves the collection efficiency and greatly reduces the measuring time of a single sound velocity profiling.

Applications



SE200

Single Beam Echo Sounder

Product Introduction

- SE200 Single beam echo sounder is a cost-effective underwater depth measurement product. Suitable for unmanned vehicle integration, it also provides an ultra-convenient solution for routine measurement applications. It is widely used in hydrology test, channel, dredging, storage capacity, river survey and other scenes



Specifications

Item	参数
Working Frequency	200kHz
Sounding Range	0.5-200m+*
Depth Resolution	8mm
Sounding Accuracy	±1cm+0.1%h
Max. Ping Rate	20Hz
Communication interface	Ethernet & RS232
Temperature Resolution	0.001°C
Data input/output mode	NMEA0183 Standard Mode
Power Supply	DC9V-32V
Power Consumption	10W
Size	Φ70mm x 105mm
Weight	1.2kg (In the air)
Software	Compatible with a variety of operating software, provide SDK development kit

* Depending on environmental conditions.

Product Features



High Accuracy

8mm depth resolution, ±1cm+0.1%h measurement depth accuracy, providing more than accurate water depth data



Easy to Use

Can be quickly deployed and installed one-click work, water depth data is easy to see



Anti-interference

Powerful anti-interference circuit, unique water depth detection algorithm and advanced interactive software is eliminated to ensure the sounding depth accuracy.



Easy Integration

A variety of data interfaces and providing SDK software to the integration use, suitable for various users in all kinds of fields

Applications

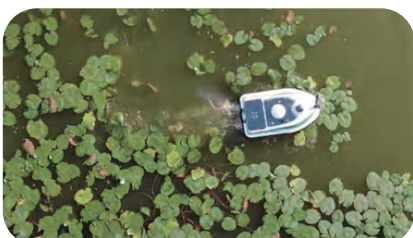

USV Deployment



Reservoir Capacity Measurement



Channel Section Measurement



Make Underwater Exploration Easier!



Website



Linkedin

Beijing Hydro-Tech Marine Technology Co., Ltd.

Building 5, No 33, Jingsheng South 2nd Street, Tongzhou Dist., Beijing, China

Tel: 86-10-5727 5310

Email: info@hydro-techmarine.com

<https://www.hydro-techmarine.com/>